



METAL-FACH
HEATING TECHNOLOGY



Technical and operational documentation
SEMAX BASIC (20-40)
Wood gasification boiler

Contents

Introduction.....	2
Symbols used in the manual	2
Introductory steps	2
General information.....	3
Application	3
Boiler equipment.....	4
Basic elements of boiler construction.....	4
Boiler dimensions.....	8
Boiler technical data.....	10
Fuel	11
Requirements for the boiler room and boiler installation	11
Boiler installation.....	13
Connection of the boiler with the heating installation.....	15
Requirements for the expansion vessel	20
Connecting the boiler to the chimney.....	20
Boiler movement	22
Please remember this when using the boiler.....	23
Boiler cleaning and maintenance.....	23
Instructions for decommissioning the boiler after its service life has expired.....	24
Spare parts list.....	24
Examples of device failure.....	24
Terms of warranty	25
Confirmation of inspection, warranty repair and service	28
EC/EU declaration of conformity.....	31
Warranty Card	33
The complaint	35
Report on the first boiler start-up	37
Report on the first boiler start-up	39

Introduction

Dear Customer, thank you for purchasing a heating boiler from METAL-FACH Technika Grzewcza Sp. z o. o . We hope that the use of the device will meet your expectations and provide you with much satisfaction. The heating boiler was designed and manufactured in accordance with applicable norms and standards, guaranteeing safe and reliable operation. Operation with strict adherence to the recommendations contained in the manual attached to the device will ensure optimal and reliable operation of the central heating boiler for many years. The product is not intended for use by persons with reduced physical/mental capabilities or lack of experience and knowledge, if they are supervised or instructed by a person responsible for their safety. Operation by children is prohibited.

Symbols used in the manual



ATTENTION!

Very important information, always read it if it appears in a given place.





TIP!

It is worth reading this information, it makes it easier to use.

Introductory steps (User)

Activities to be performed when accepting the METAL-FACH Technika Grzewcza Sp. boiler. z o. o .:

- check whether the delivered boiler is complete (Chapter: Boiler equipment) and whether the boiler has not been damaged during transport,
- compare the nameplate mounted on the boiler casing on the left or right side with your order,
- carefully - it contains information needed for the proper use of the boiler.

		Technika Grzewcza Sp. z o.o. 16-100 Sokółka ul. Sikorskiego 66 tel/fax 85 711-94-54 www.metalfachtg.com.pl	
		KOCIOŁ GRZEWCZY SEMAX BASIC	
Typ kotła	SEMAX BASIC	Przyłącze elektryczne	2A/230V/50Hz
Model	-	Klasa kotła	5
Nr fabryczny	-	Dopuszcz. ciśnienie [bar]	3
Data produkcji	-	Temp. max. [°C]	80
Moc nominalna [kW]	-	Poj. Wodna [L]	-
Zakres mocy [kW]	-	Pobór mocy praca/rozpalanie [W]	-
Typ pracy	-	Kategoria kotła	-
Nominalne Obciążenie cieplne	-	Zakres dopływu ciepła	-
Rodzaj paliwa	Szczapy drewna liściastego (tablica 9 normy PN-EN 303-5:2021:09 wilgotność 12-20%, zawartość popiołu ≤1%, wartość opałowa 17MJ/kg		
			

If you encounter any problems, please contact the service department or the authorized service of METAL-FACH Technika Grzewcza Sp. z o. o .. These people have appropriate training and access to original parts enabling proper service and installation of METAL-FACH Technika Grzewcza Sp. boilers. z o. o ., confirmed by a certificate issued at the company's headquarters.

General information
(User)

Technical and Operational Documentation is one of the parts of the product, delivered with the purchased central heating boiler. The Technical and Operational Documentation contains data on the construction, assembly and use of SEMAX BASIC boilers. Careful reading of the user manual ensures correct and safe use of our boiler.



ATTENTION!

The user is advised to follow all instructions regarding the device contained in this Technical and Operational Documentation, the Warranty Conditions and generally applicable legal regulations.

The boilers are delivered assembled. They are set and attached to the pallet permanently. Additional security measures are used in the form of foil packaging.

When transporting the boiler, it should be secured against shifting or rotation on the car's cargo bed using safety equipment, e.g. belts. Transport of boilers should be carried out in accordance with the rules regarding the transport of materials. Loading and unloading must be carried out using lifting equipment (forklift) with a capacity of more than 1000 kg.

Application
(User | Installer)

The boiler is designed to supply heat to central heating systems (radiator and underfloor heating) and to obtain domestic hot water. The boiler should operate at full rated power in a system with a buffer storing excess heat. The drawing shows an example diagram of a boiler with a buffer. Operating the boiler at nominal power allows for better fuel utilization and better exhaust gas quality for the atmosphere . Correct operation and achievement of the boiler's full capabilities depend on the quality of the installation, appropriate chimney draft, and proper operation and maintenance of the boiler.



ATTENTION!

The boilers are intended for operation in open and closed water systems with gravity or forced circulation, with protections in accordance with the requirements of the applicable standard PN-B-02413 Heating and District Energy and a closed system in accordance with the standard PN-EN 12828 Heating installations in buildings. Projects.



ATTENTION!

The heating system must have a buffer to store excess heat!

Boiler equipment
(User)

The scope of delivery includes both basic and additional elements, depending on the order placed. Upon receipt, carefully inspect the product to check whether it has been damaged during transport and check whether the equipment is complete. The elements included in the basic and additional equipment are listed below.

Basic equipment:	Unit of measurement	Quantity
Central heating boiler	pcs .	1
Thermometer	pcs .	1
Boiler leveling feet	pcs .	4
Boiler cleaning tools: <ul style="list-style-type: none"> • poker • brush • scraper 	set .	1
Documentation:	Unit of measurement	Quantity
Technical and operational documentation of the boiler	pcs .	1



ATTENTION!

The user should carefully read the operating instructions for the controller and the fan.



ATTENTION!

METAL-FACH Technika Grzewcza Sp. z o. o . reserves the right to introduce changes in technical parameters, equipment and specifications of the offered goods without prior notice.

Basic elements of boiler construction
(User | Installer)

The appearance and structure of the boiler are shown in the technical drawing. Some parts of the boiler are marked with numbers in the drawing.

There are four doors on the front wall of the boiler:

- Cleaning door (1) allowing access to cleaning and observing the boiler convection channels.
- Loading door (2) needed for filling the boiler with firewood, cleaning and observing the combustion chamber. An air damper (17) is built into the door.
- Grate doors (3) and pre-grate doors (20) allow for the arrangement and ignition of the ignition layer, scaffolding , cleaning and observation of the combustion chamber and the condition of the cast iron grate (19). The door has a built-in hinged flap (16), which regulates the supply of primary air for fuel combustion. The flap can be raised or lowered using the built-in knob.
- Ash pan door (4) enabling removal of the drawer (21) with ash and cleaning of the ash pan
- A cable (5) used to close and open the smoke exhaust flap (13) of the loading chamber while fuel is being added to the boiler. When open, the flap allows exhaust gases to be discharged via a shorter path to the chimney. The flap must be closed during boiler operation.

On the rear wall of the boiler there are:

- Connector (10) with ¾" internal thread for filling and draining water from the boiler.
- Connector (12) with 1½" internal thread, which is the return connector of water from the central heating system

- Secondary air intake (9), where the air needed for complete combustion of the fuel is sucked in through 6 holes. The amount of air can be adjusted with the sliders (18).
- Flue with cleanout (8).

On the upper wall of the boiler there are:

- The connector (11) with a 1½" internal thread is a connector that supplies hot water to all heat receivers connected to the boiler.

There are plugs on the left and right walls of the boiler that allow access to the protection (24) of the ceramic channel. The protection should be removed if it is necessary to replace the channel plates.

Boiler interior:

- Ceramic channel (15), in which combustion and post-combustion of gases produced in the combustion zone on the boiler grate take place. **As a result, these are wood gasification boilers.**
- Smoke exhaust flap (13).

SEMAX BASIC boiler

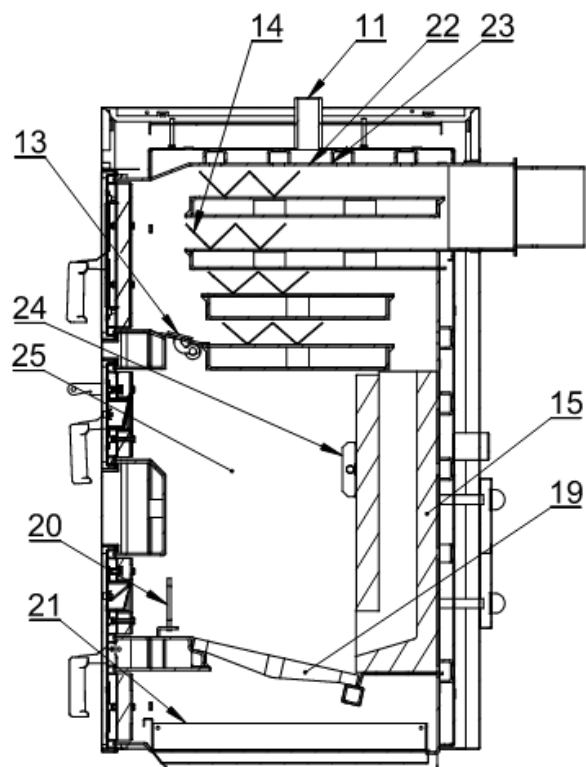
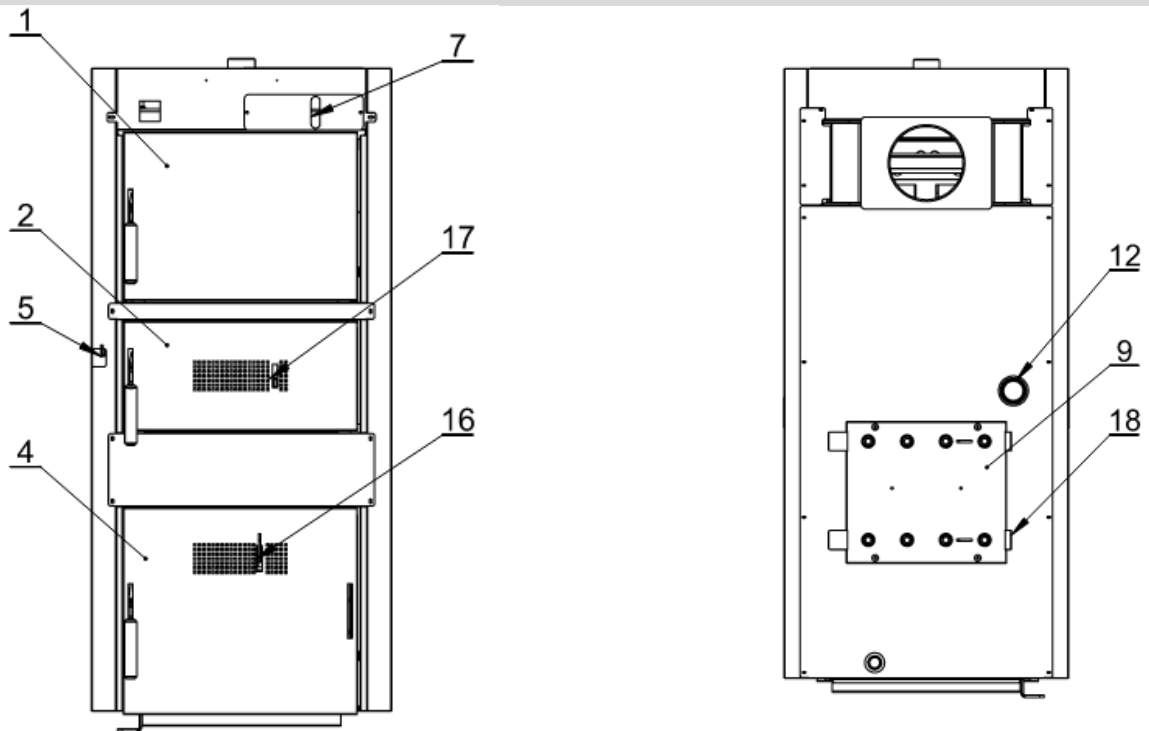

Cross-section of the SEMAX BASIC 20,30,40 boiler

- | | |
|-----------------------------|---------------------------------------|
| 1. The door is clean | 13. Smoke exhaust flap |
| 2. Loading door | 14. Exhaust gas swirler |
| 3. Slatted doors | 15. Ceramic channel |
| 4. Ash pan door | 16. Primary air supply flap |
| 5. Smoke exhaust flap cable | 17. Primary air supply flap |
| 6. - | 18. Secondary air supply regulation |
| 7. Draft regulator | 19. Cast iron grate |
| 8. - | 20. Pre-slat door |
| 9. Secondary air intake | 21. Ash pan drawer |
| 10. Drain port | 22. Boiler temperature sensor sleeve |
| 11. Supply connector | 23. STB sensor sleeve |
| 12. Return connector | 24. Protection of the ceramic channel |
| | 25. Loading chamber for firewood |

Boiler dimensions
(User | Installer)

SEMAX BASIC boiler

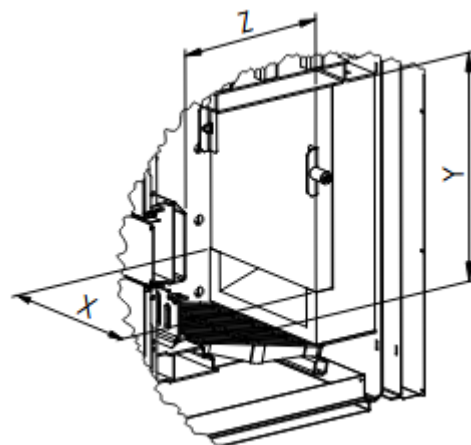
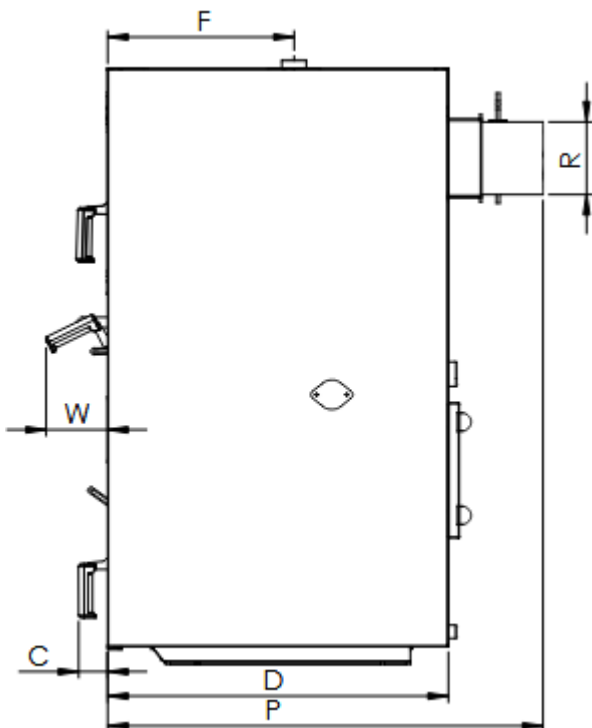
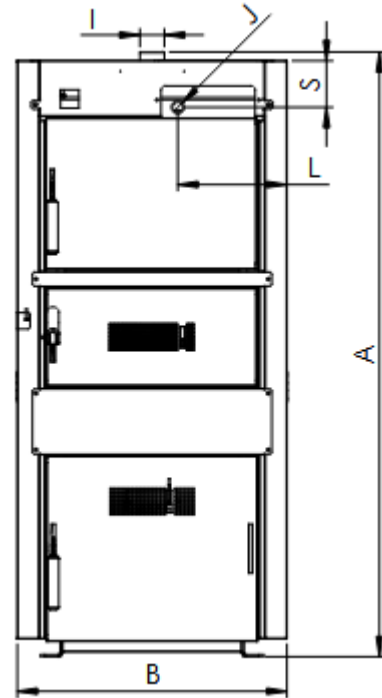
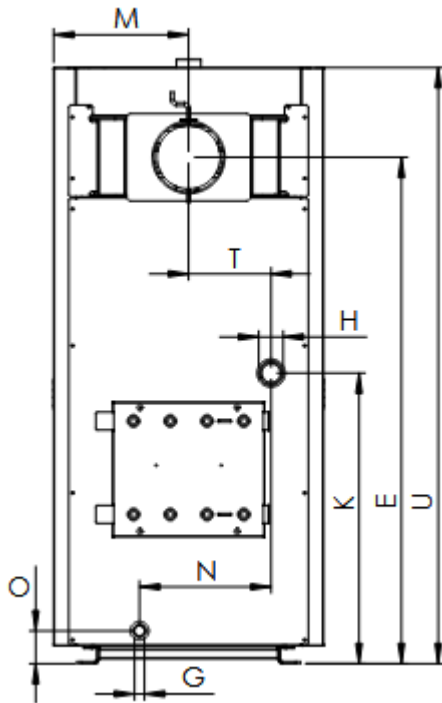

Type	SEMAX BASIC 20	SEMAX BASIC 30	SEMAX BASIC 40
A	1275	1480	1480
B	520	560	660
C	70	70	70
D	835	835	835
E	1050	1240	1240
F	455	455	455
G	3/4"	3/4"	3/4"
H	1 1/2"	1 1/2"	1 1/2"
I	1 1/2"	1 1/2"	1 1/2"
J	3/4"	3/4"	3/4"
K	713	713	713
L	137	217	267
M	255	280	330
N	222	222	322
O	80	80	80
P	1070	1070	1065
R	159	177	177
S	114	114	114
T	102	102	202
U	1255	1460	1460
W	150	150	150
X	290	340	440
Y	515	590	590
Z	445	420	420
Loading opening	290x200	340x200	440x200

*The dimensions do not include the height of the boiler leveling feet .

Boiler technical data (User | Installer)

Parameters	SI unit	Boiler model		
		SEMAX BASIC 20	SEMAX BASIC 30	SEMAX BASIC 40
Nominal thermal power	[kW]	20	30	40
Heating surface	[m ²]	2,8	4,2	4,9
Water capacity	[L]	77	99	116
Maximum working pressure	[bar]	3	3	3
Maximum operating temperature	[°C]	80	80	80
Test pressure	[bar]	4,5	4,5	4,5
Boiler class	-	5	5	5
Boiler efficiency	[%]	-	-	-
Fuel	[-]	Firewood - logs (logs) with humidity Wc = 12-20%		
Perimeter of logs (logs)	[cm]	30-40		
Log length (logs)	[cm]	36	34	34
Electrical connection	-	1A; ~230V; 50Hz		
Temperature controller setting range	[°C]	60-80 (every 1°C)		
Chimney draft required	[Pa]	22	25	28
Calculated flow resistance ΔT [10K]	[mbar]	12,3	24,75	29,83
Calculated flow resistance ΔT [20K]	[mbar]	3,8	5,05	7,45
Boiler weight *	[kg]	390	415	500
Heat storage capacity (buffer)	[L]	780	1230	1680

*Boiler weight +/- 5kg.

Fuel **(User)**

The fuel for firing the boiler is logs and hardwood logs, dimensions and humidity are given in the "Technical data of the boiler" chapter.

- Humidity 12 – 20%,
- content \leq 1%,
- circumference 30 – 40 cm,
- length of logs 26 cm,
- value >17 MJ/kg.

Requirements for the boiler room and boiler installation **(User | Installer)**

In Poland, boiler rooms built for solid fuel should meet the requirements of the standard PN-87/B-02411 "Boiler rooms built for solid fuel" and Journal of Laws 2015.0.1422. They are divided into two types:

1. For small boiler rooms up to 25 kW of power, the following requirements should be met:
 - the boiler should be located as centrally as possible in relation to the heated rooms and in a separate room;
 - the material from which the floor in the boiler room will be made should be non-flammable; in the case of flammable material, the floor should be covered with a 0.7 mm thick steel sheet at a minimum distance of 50 cm from the edge of the boiler; the boiler should be placed on a foundation made of non-flammable materials, protruding 0.05 m above the floor level and edged with steel angles;
 - there should be artificial lighting in the room, natural lighting is also recommended;
 - placing the wheel in the room should allow free access to the boiler during cleaning and maintenance; the distance from the back of the boiler to the wall should not be less than 70 cm, the side of the boiler from the wall not less than 100 cm, and the front of the boiler from the opposite wall not less than 200 cm;
 - the height in new buildings should be at least 220 cm, in the case of existing buildings, the height of the boiler room is at least 190 cm, with proper ventilation (supply and exhaust) ensured;
 - ventilation should take place through an unclosed opening with a cross-section of at least 200 cm² and located up to a maximum of 100 cm above the floor level;
 - ventilation should be provided through an exhaust duct made of non-flammable material with a minimum cross-section of 14 x 14 cm with an inlet opening under the ceiling of the boiler room; the exhaust duct should be led above the roof and placed near the chimney; there cannot be devices on the exhaust duct that allow it to be closed;
 - the cross-section of the chimney should be not less than 20 x 20 cm;
 - there should be a floor drain in the floor of the boiler room;
 - the optimal place for fuel storage is a separate room located near the boiler room;
 - ash and slag should be collected in appropriate containers that can be emptied daily.
2. Boiler rooms with a thermal power of 25 kW should additionally meet the following requirements:
 - the distance of the furthest boiler from the chimney, with gravity draft, cannot exceed 50 cm of the chimney height;
 - storage and slag storage should be located next to the boiler hall at a storage height of up to 220 cm with a free space above the fuel of at least 50 cm;
 - devices and equipment enabling vertical and horizontal transport of fuel and slag should be taken into account;
 - room should have natural, unforced ventilation, enabling one complete air exchange per hour in the fuel storage room and three complete air changes per hour in the slag storage room;

METAL-FACH Heating Technology

- doors to the boiler room should be non-flammable (fire resistance class 0.5), minimum width 80 cm, opening outwards; they should have a handleless closing system enabling them to be opened outwards under pressure and inwards using a handle;
- ventilation requirements are the same as for boiler rooms with lower power; additionally, in boiler rooms with a power exceeding 400 kW, in addition to supply and exhaust ventilation, there should be mechanical ventilation, switched on periodically when feeding fuel and removing slag from the boilers, ensuring at least 10 full air changes per hour;
- in the boiler room, natural lighting should be taken into account, illuminating the boiler from its front, and the window area should be at least 1/15 of the boiler room floor area; half of those installed should be openable; electric lighting and an electrical socket with a voltage not exceeding 24 V should also be located in the room;
- there should be a sewage well in the floor allowing for water cooling, and its capacity should be equal to the water capacity of the largest boiler, but not more than 2 m³;
- in the boiler room, heat pipes should be insulated;
- Boiler positioning with the minimum required distances is shown in the boiler room diagram below.

Minimum distances for placing the boiler in the boiler room

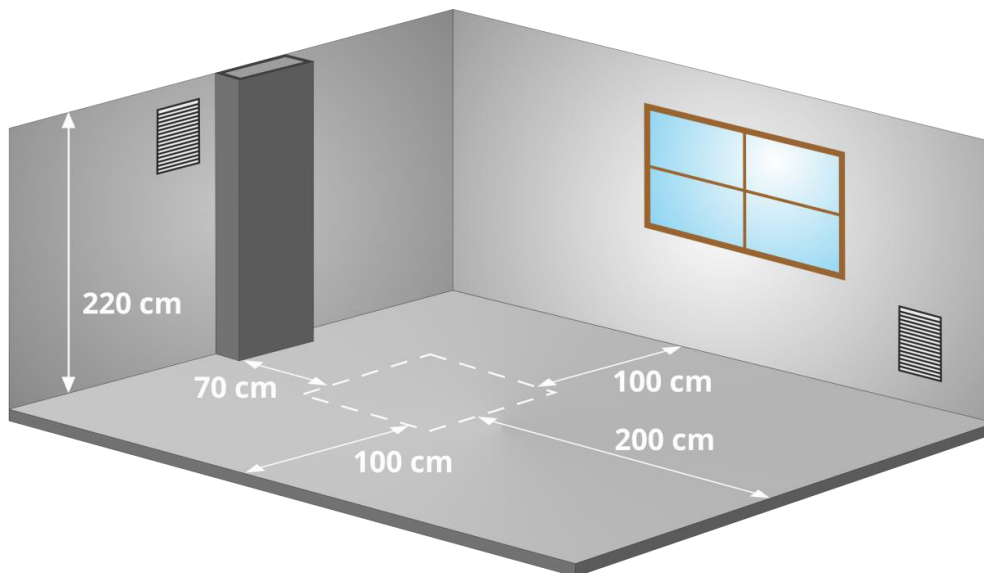

ATTENTION!

Mechanical exhaust ventilation should not be used in the boiler room.



ATTENTION!

Ensuring the supply of sufficient fresh air to the boiler room will enable effective fuel combustion.



ATTENTION!

It is necessary to prevent the formation of excessive amounts of carbon dioxide in the room.

**ATTENTION!**

More detailed information regarding the requirements for the construction of a boiler room can be found in the Regulation of the Minister of Infrastructure of March 12, 2009.

**TIP!**

The above-mentioned provisions are guidelines that need to be verified as the regulation is subject to amendment.

Boiler installation**(User | Installer)**

An important element of the installation is the correct positioning and leveling of the SEMAX BASIC boiler; these boilers do not require special foundations. Leveling the boiler is made easier by adjustable feet. The boiler must stand vertically.

1. Check whether the set includes four feet.
2. Use a spirit level to level the boiler in relation to the ground. If the boiler is in a horizontal position, the installation of feet is not required.
3. Screw the four feet into the designated holes.
4. Use a spirit level to level the boiler

How to install boiler leveling feet

1. Adjustable foot, 4 pcs
2. M10 nut, 8 pcs
3. Washer Ø10, 8 pcs

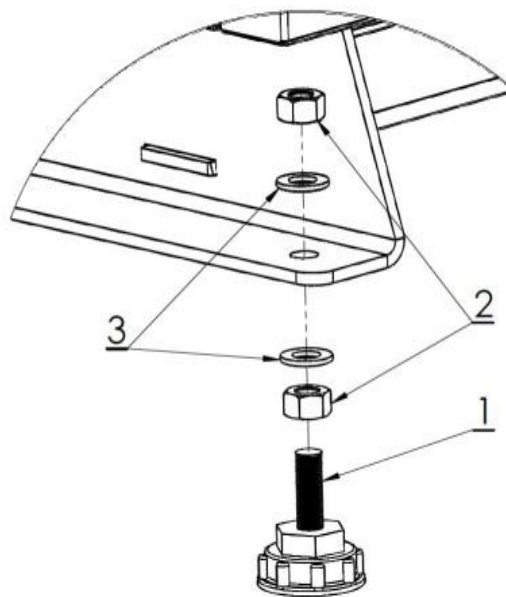

ATTENTION!

An incorrectly leveled boiler may be damaged.



ATTENTION!

It is unacceptable to place the boiler in a humid or wet room, as this accelerates corrosion, leading to the destruction of the boiler in a short time.

The boiler should be placed on a heat-insulating, non-flammable pad, which on each side of the boiler should be 2 cm larger than the boiler base . If the boiler is located in the basement, it is recommended that it be placed on a foundation of at least 5 cm. Substrate strength as well as fire protection conditions. are key guidelines when placing the boiler in the right place, they include:

- 20 cm safe distance from flammable materials,
- 40 cm for flammable materials with flammability grade C3,
- 40 cm if the flammability level is not known.

The degree of flammability of building masses and products	Building masses and products
A - Non-flammable	Sandstone, concrete, bricks, fireproof plaster, mortar, ceramic tiles, granite
B - Hard to burn	Wood-cement boards, glass fibers, mineral insulation
C1 - Hard to burn	Beech wood, oak wood, plywood
C2 - Medium burning	Pine, larch and spruce trees cork, sawn wood boards, rubber floor coverings
C3 - Easily flammable	Asphalt plywood, celluloid masses, polyurethane, polystyrene, polyethylene, plastic, PVC

Connection of the boiler with the heating installation (Installer)

The boiler should be connected to the central heating system by a company authorized by the manufacturer, and the correct connection should be confirmed on the warranty card attached to this manual. The boiler should be connected according to the manufacturer's recommendations and in accordance with these instructions.



ATTENTION!

It is recommended that the boiler be started for the first time in accordance with the guidelines contained in the Technical and Operational Documentation by a person with valid authorizations - (Information on persons authorized to start the boiler is available from the Manufacturer - tel. +48 85 711 94 54 ext. 17).



ATTENTION!

The temperature of water returning from the installation to the central heating boiler should not be lower than 45°C.



ATTENTION!

Installation of an APV valve is required (min. 45°C)

Diagrams of connecting boilers to the heating installation in accordance with the PN - 91/B – 02420 standard

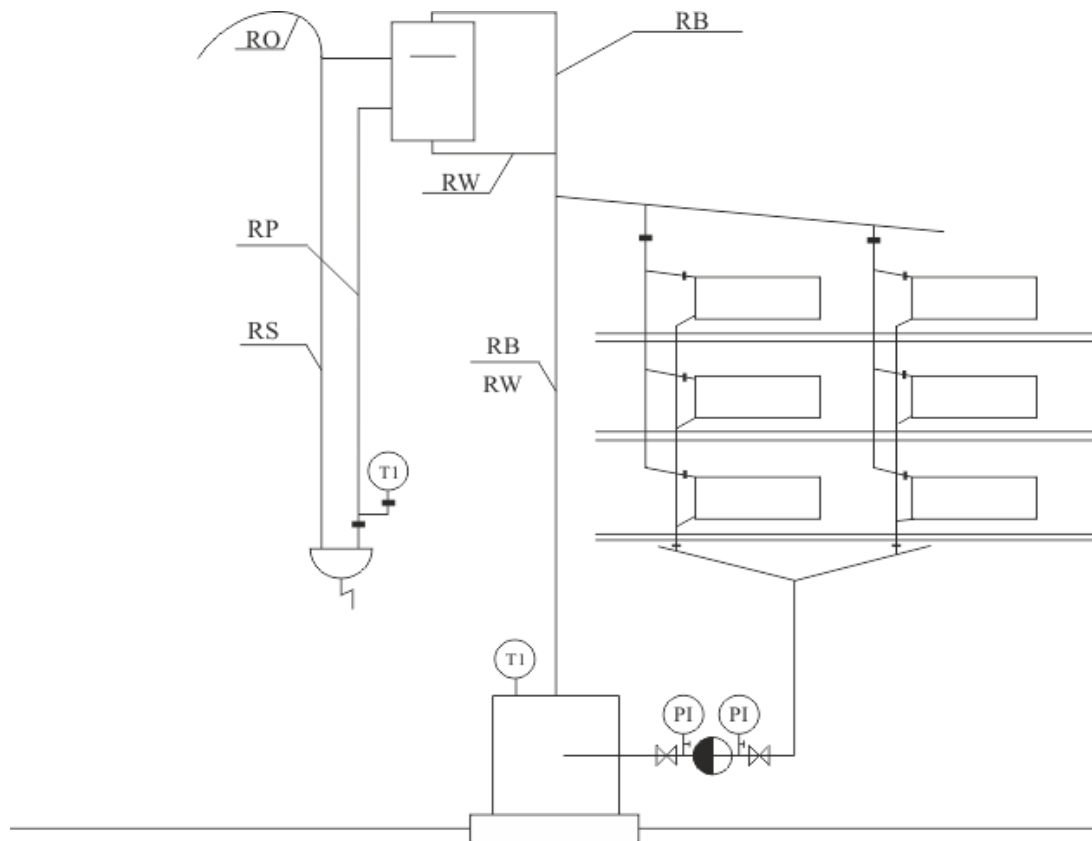

Designation	Description
RO	Vent pipe
RW	Expansion pipe
RS	Signaling pipe
RP	Overflow pipe
RB	Safety pipe
T1	Temperature
P1	Pressure

Diagrams of connecting boilers to the heating installation in accordance with the PN - 91/B – 02420 standard

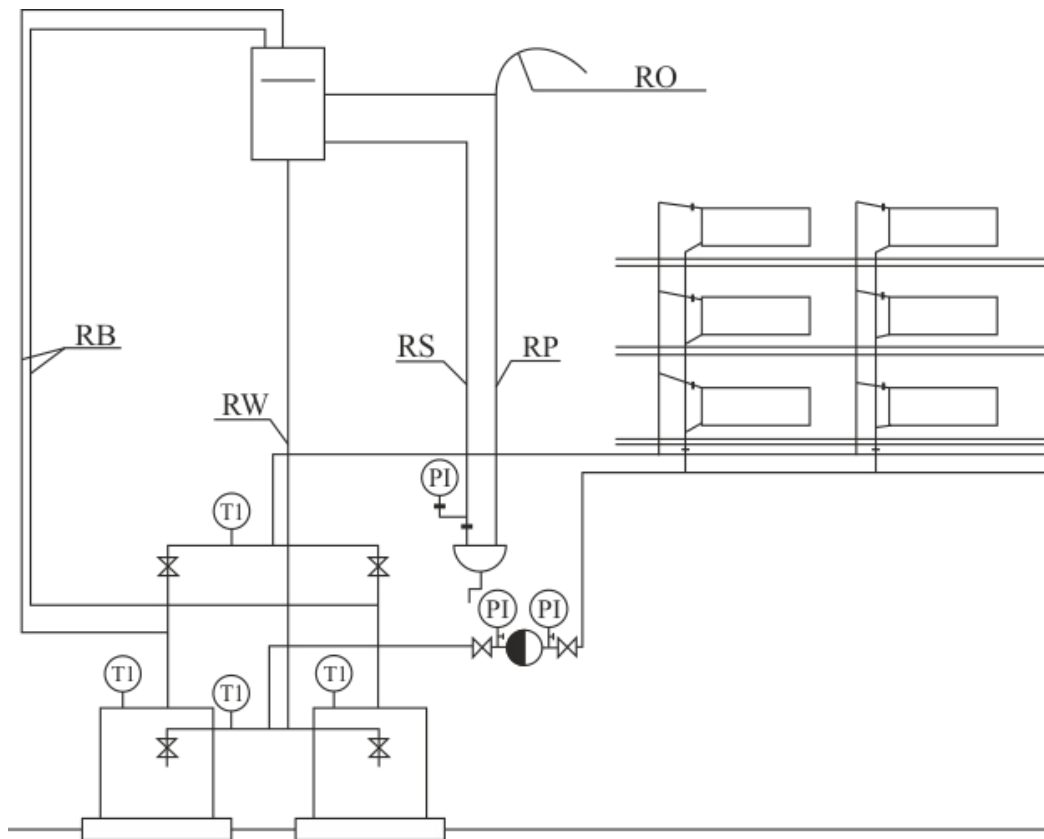

Designation	Description
RO	Vent pipe
RW	Expansion pipe
RS	Signaling pipe
RP	Overflow pipe
RB	Safety pipe
T1	Temperature
P1	Pressure

Boiler connection diagram in a system with a buffer (DHW before the buffer)

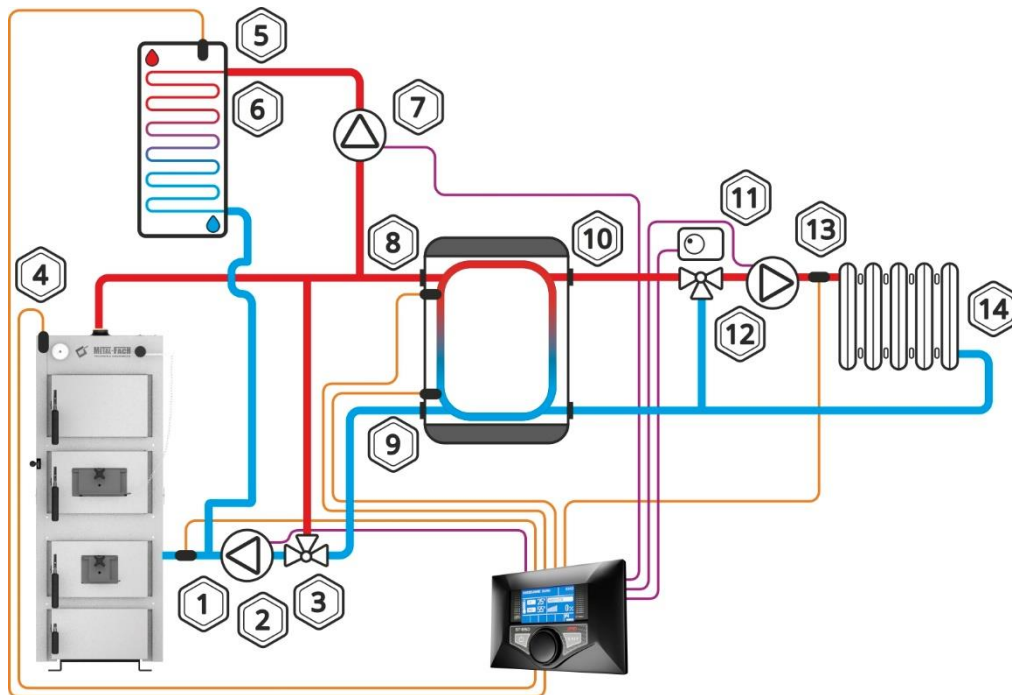

- | | |
|--|---|
| <ul style="list-style-type: none"> 1. Return sensor 2. Central heating pump 3. 3D thermostatic valve 4. Boiler sensor 5. Central heating sensor u . 6. Heater 7. Central heating pump u . | <ul style="list-style-type: none"> 8. Upper buffer sensor 9. Lower buffer sensor 10. Buffer 11. 3D valve with actuator 12. Mixer pump 13. Mixer sensor 14. Heating circuit |
|--|---|

Boiler connection diagram in a system with a buffer (DHW after the buffer)

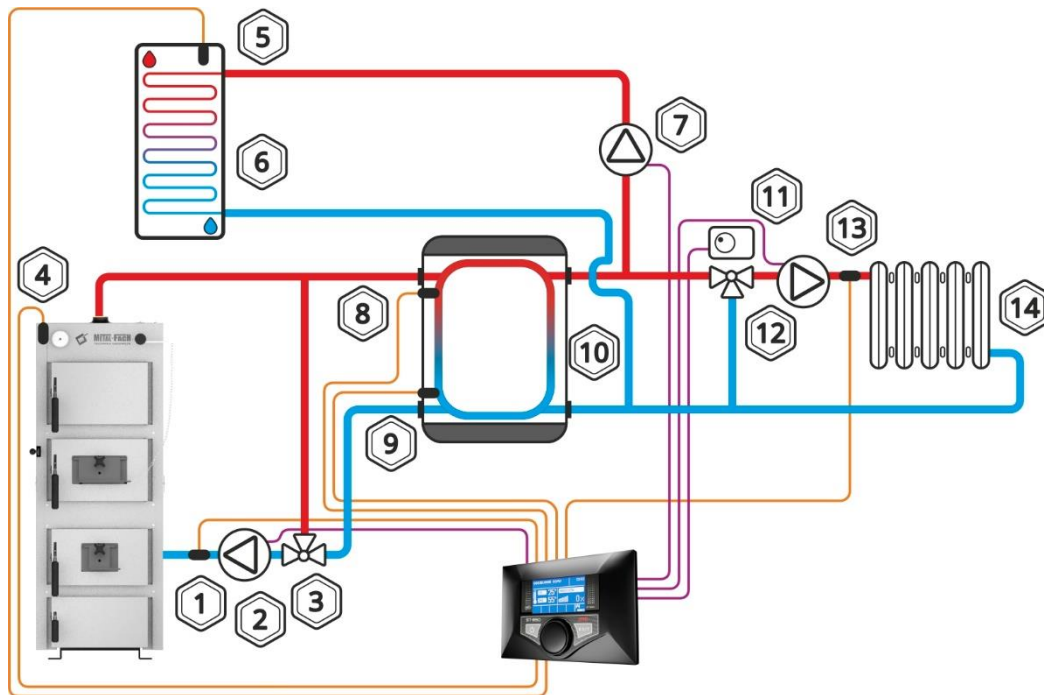

- | | |
|-------------------------------|----------------------------|
| 1. Return sensor | 8. Upper buffer sensor |
| 2. Central heating pump | 9. Lower buffer sensor |
| 3. 3D thermostatic valve | 10. Buffer |
| 4. Boiler sensor | 11. 3D valve with actuator |
| 5. Central heating sensor u . | 12. Additional pump |
| 6. Heater | 13. Mixer sensor |
| 7. Central heating pump u . | 14. Heating circuit |

Requirements for the expansion vessel (Installer)

Each open system heating installation should be equipped with an expansion vessel, the task of which is to absorb the increase in the volume of water filling the installation and vent it. This vessel should be installed at the highest point of the installation, if possible in a vertical line above the boiler(s). The volume of the expansion vessel can be estimated by assuming the unit capacity in relation to one kW of thermal efficiency is 1-2 dm³. The expansion vessel is equipped with a stub pipe for connecting the rising safety pipe, the falling safety pipe and the overflow pipe and the connected vent. The diameter of the vent pipe and overflow pipe is at least:

$$d = 15 + 1,39 \sqrt{\dot{Q}} \quad [\text{mm}]$$

\dot{Q} - boiler efficiency [kW]

The most important requirements for safety devices are as follows:

- the expansion tank should have a volume of approximately 3.5% of the volume of water in the heating system including the boiler,
- each boiler should absolutely have a safety pipe and an overflow pipe,
- the installation should be equipped with a signaling and expansion pipe and a vent connector for the expansion vessel.

If several boilers are installed, each of them should be equipped with a safety pipe in accordance with the principles specified in PN-91/B02413 - protection of open system water heating installations. No shut-off valves may be installed on safety and overflow pipes, and the pipes and vessel must be protected against freezing.

Connecting the boiler to the chimney (Installer)

Smoke pipes

The purpose of the smoke ducts is to reliably discharge exhaust gases outside and suck in air enabling fuel combustion. The chimney draft required for this depends on:

- difference between hot exhaust gases and cold air;
- effective height of the chimney;
- cross-section not less than 20 x 20 cm;
- the construction of the chimney (possibly smooth internal surfaces) and the tightness of the joints;

The effective height of the chimney is the height difference between the highest fireplace and the chimney exit. The effective height of individual chimneys must be at least 4 m, and of common chimneys for solid and liquid fuels, at least 5 m. The difference in height between two fireplaces cannot be greater than 6.5 m. In the case of sloping roofs, the chimneys should end at within the ridge (the highest point of the roof), in the area of free wind flow. This prevents draft disturbances. Always pay attention to the position of the building in relation to other buildings.

Chimney selection

In most cases, an approximate method or selection according to the chimney manufacturer's diagrams is sufficient to select a chimney. In special cases (unfavorable pressure and temperature relationships, large volume of exhaust gases), chimneys are calculated in accordance with the PN-EN 13384-1+A2:2008 standard.

Chimneys for solid fuel boilers

Please note that solid fuel furnaces with a nominal thermal power of >20 kW and without a fan require their own chimney. Single-layer brick chimneys can be used for solid fuel fireplaces. Currently, three-layer chimneys are used with a smooth surface and good thermal insulation.

Chopuch

The boiler is connected to the chimney by a flue and a smoke duct. A flue consists of pipes and fittings that are placed in rooms. Flues meet fire protection requirements for chimneys and are often made of the same material as the main chimney. Smoke ducts should be made of non-flammable products. The ducts or casing of smoke ducts should meet the requirements specified in the Polish Standard for fire tests of small chimneys. It is allowed to make the casing of 12 cm thick full brick, built on cement-lime mortar, with external plaster or grouting. Connectors should be as short as possible and placed with a slope towards the chimney to avoid heat loss and additional resistance. They cannot be led to other floors. Exhaust gas pipes should not be placed in rooms where fireplaces cannot be installed, and they should not be placed in walls or ceilings. Due to the low temperature of exhaust gases, acid-resistant or ceramic chimney inserts with condensate drainage to the sewage grate should be used to protect the chimney against moisture and reduce draft. A distance of at least 6 m should be maintained between the chimney and the nearest edge of the tree crown .

Boiler movement (User | Installer)



ATTENTION!

The controller settings are freely adjustable due to the variety of existing central heating installations, the building's heat demand as well as the calorific value of the fuel. The user sets the boiler operating parameters himself. This activity is not subject to service.

Before lighting a fire in the boiler, check whether the central heating installation was made correctly and whether it is filled with water correctly - until it is poured through the overflow pipe from the expansion vessel .

To fill the entire installation or fill gaps, the most suitable solution would be softened water/chemically treated water, distilled water or rainwater.

Additionally, check whether the ash has been removed from the ash pan.

The SEMAX BASIC boiler is a bottom combustion boiler, i.e. the exhaust gas outlet from the charging chamber is located in the lower part, right next to the grate. Smoke exhaust flap located in the upper part of the boiler; it is only used to exhaust smoke from the chamber when refuelling while the boiler is operating and can never be used as a convection channel during combustion.

The kindling should be placed on the grate right next to the exhaust gas outlet into the ceramic channel. Before lighting the kindling, you should:

- Check whether the smoke exhaust flap (13) is closed.
- Turn on the controller to start the exhaust fan and create chimney draft.
- Lift the flap (16) in the ash door (4) as far as possible or open the door.
- Close the secondary air supply in the air intake (9).
- Light the kindling.

When the first ignition portion catches fire, add a little more fuel to it. If the entire inlet to the ceramic channel is covered with hot fuel, the entire chamber can be filled with it.

Each time you add fuel, i.e. open the loading door (2), remember to first open the smoke exhaust flap (13) and close it immediately after this operation. After that, you can open the secondary air supply in the air intake (9), close the ash door, leaving the flap (16) open and held by a knob.



ATTENTION!

Smoke and tar on the walls of the charging chamber in this type of boiler (with bottom combustion) should be treated as a normal phenomenon. This does not affect the boiler's efficiency or durability, but is only an aesthetic phenomenon.



ATTENTION!

When opening the door, do not stand in front of the boiler, as it may cause burns.

Please remember this when using the boiler**(User)**

- the boiler may only be operated by adults who have read the operating instructions;
- are prohibited from staying near the boiler without the presence of adults;
- if flammable gases or vapors enter the boiler room or during work during which there is an increased risk of fire or explosion (gluing, painting, etc.), the boiler should be turned off before starting the work;
- when cleaning carbon deposits in the burner or gutter, the boiler should be turned off ("STOP" position);
- when adding fuel to the tank, the boiler should be turned off ("STOP" position);
- to light the boiler, the boiler should ignite automatically (using an igniter);
- before cleaning the boiler, the device should be turned off ("STOP" position) and cooled down;
- the boiler must not be overheated in any way during operation;
- flammable objects must not be placed on the boiler or in its immediate vicinity;
- when removing ash, flammable materials cannot be closer than 150 cm from the boiler;
- ash should be placed in heat-resistant dishes with a cover;
- when the boiler is operated at a temperature lower than 60°C, condensation of the steel exchanger may occur and thus cause corrosion as a result of the low temperature, which shortens the life of the exchanger; therefore, the temperature during boiler operation must be at least 60°C;
- after the end of the heating season, the boiler and the smoke duct should be thoroughly cleaned;
- the boiler room should be kept clean and dry.

**ATTENTION!**

The product is not intended for use by persons with reduced physical/mental capabilities or lack of experience and knowledge, unless these persons are supervised or instructed by a person responsible for their safety.

**ATTENTION!**

Any independent interference in the electronics or the structure of the boiler is prohibited.

Boiler cleaning and maintenance**(User)****ATTENTION!**

The boiler can only be cleaned with the device disconnected from the electrical network.

To save fuel, keep the combustion chamber and boiler convection channels clean. In the combustion chamber, clean the walls and shelves through the cleaning and inspection doors. The boiler exchanger and ash pan are also regularly cleaned.

Cleaning should be done using wire brushes on extension cords. The above activities should be performed during periodic boiler shutdown, preferably every 100 hours of boiler operation. The boiler should be thoroughly cleaned once a month.

Instructions for decommissioning the boiler after its service life has expired (User)

Before scrapping the boiler, disconnect all electronic components from it. They are disposed of in accordance with the European Directive 2002/96/EC concerning the consumption of electronic and electrical equipment. For proper disposal, please contact the manufacturer of electronic components in accordance with the above-mentioned European Directive.

Steel elements from which the boiler is made should be scrapped in designated places (scrap collection).



ATTENTION!

A used boiler intended for scrapping and its components should not be disposed of with general waste.

Spare parts list (User | Installer)

Spare parts	Article
Instrumentation	Door handle

Examples of device failure (User)

Before calling the service, please read the most frequently asked questions.



Online application: www.metalfachtg.com.pl/zglos-problem-online



Hotline: +48 85 711 94 54 ext. 17



Instructional videos: www.youtube.com/c/METALFACHTechnikaGrzewcza



FAQ: www.metalfachtg.com.pl/kontakt-z-serwisem/#faq

Terms of warranty (User)

User Statement:

I hereby declare that the boiler (hereinafter also referred to as the "device") was delivered to me in accordance with the order, new and complete. The seller familiarized me with the operation of the device and provided me with a complete set of documentation (including in particular: Technical and Operational Documentation containing, among others, instructions for installation and operation of the device, warranty conditions). I acknowledge the manufacturer's recommendation that the device be subjected to regular annual technical inspections, which should be confirmed in the warranty card.

Date and legible signature of the User

Warranty scope:

1. Liability under the warranty covers only defects resulting from reasons inherent in the device at the time of its delivery to the User.
2. The warranty for the device is provided by the manufacturer (also called the "Guarantor"): Jacek Kucharewicz, running a business under the name METAL-FACH Technika Grzewcza Sp. z o. o., 16-100 Sokółka, ul. Sikorskiego 66, NIP: 545-182-60-12, REGON 050073833, phone +48 85 711 94 54 ext. 17.
3. Under the warranty, the User is entitled to have the device repaired free of charge if device defects are revealed during the warranty period. If the Guarantor finds it impossible to repair the device or its parts, the Guarantor reserves the right to replace the device or its parts with a new one.

Guarantee period:

For the device (boiler) - 2 years from the date of sale, but no longer than 36 months from the date of its production, except for:

- a) exchanger – for which the warranty is 5 years from the date of sale;
- b) moving, cast iron, mechanical elements, screw - for which the warranty is 1 year from the date of sale;
- c) consumable elements (including sealing cord, seals, verniculite, fireclay), electrical components, screw securing the auger clutch, cotter pins - which are not covered by the warranty.

Terms of use of the warranty:

1. Installing the device in accordance with the Technical and Operational Documentation (in particular, connecting the boiler to a properly installed installation, performing the first start-up in accordance with the device manufacturer's guidelines, using devices protecting the boiler against the return of cold water (four-way valve with an actuator, icedomat, etc.)
2. Sending a copy of the correctly completed warranty card, signed and stamped by the seller, to the Manufacturer's address within 30 days from the date of sale of the device
3. When submitting a complaint, presenting a correctly completed warranty card (signed and stamped by the seller) and substantiating the circumstances of the purchase of the device (e.g. receipt, invoice). If the User loses the warranty card, a duplicate will not be issued.
4. The User follows the recommendations contained in the Technical and Operational Documentation of the device.
5. Performing the first boiler start-up, within 6 months from the date of installation of the device by the installer in accordance with the guidelines contained in the Technical and Operational Documentation, by a person with valid authorizations (Information on persons authorized to start the boiler is available from the Guarantor +48

85 711 94 54 ext. 17) , confirming this fact in the warranty card and sending the commissioning report to the Guarantor. The first start-up of the boiler is a paid service and its cost is covered by the User.

6. Carrying out annual inspections of the device, in accordance with the guidelines contained in the Technical and Operational Documentation, by specialist companies with appropriate authorizations (an example list of specialist companies is available from the Manufacturer - at +48 85 711 94 54 ext. 17 and recording their performance in the warranty card. The inspection of the device is paid service.
7. Performing service of the device (e.g. device adjustment, cleaning, measurements, exhaust gas analyses) by specialist companies with appropriate authorizations (a sample list of specialist companies is available from the Manufacturer - at +48 85 711 94 54 ext. 17), in accordance with the guidelines contained in the Technical Documentation Ruchowa and recording service services in the warranty card. The User may report the need for service interventions to the Guarantor (Helpline +48 85 711 94 54 ext. 17, [www.metalfachtg . pl /zglos-problem-online](http://www.metalfachtg.pl/zglos-problem-online)). The service is available for a fee.
8. Warranty repairs are carried out only by specialist companies with appropriate authorizations (the list of specialist companies is available from the Guarantor - tel. +48 85 711 94 54 ext. 17), and they are recorded in the warranty card.
9. Use of spare parts and consumables that meet the parameters specified by the manufacturer. It is recommended to use original parts.
10. The warranty covers the territory of the Republic of Poland.

The warranty does not cover device defects resulting from:

1. Failure by the User to comply with the conditions contained in the Technical and Operational Documentation and contained therein, among others: instructions regarding transport, assembly, operation, operation and maintenance of the device;
2. Inappropriate storage and transport by the User;
3. Damage to device components due to the use of incorrect electrical voltage by the User. If the device is powered directly or indirectly by generators, UPS systems or devices, the User should consult the parameters of the power supply devices with the manufacturer;
4. Device defects caused by a faulty heating installation connected to the device;
5. Overheating of the boiler by the User;
6. The User connects the boiler to a closed system without using an appropriate cooling device;
7. The User uses inappropriate, poor quality fuel;
8. Unauthorized modifications to the device by the User.

Complaint procedure:

1. If incorrect operation of the device is found, before submitting a complaint, make sure that everything has been done in accordance with the Technical and Operational Documentation.
2. The User should report the need to repair the device under warranty immediately, preferably within 7 days from the date of noticing the defect. Reports may be made directly to the Seller or the Guarantor ([www.metalfachtg . pl /zglos-problem-online](http://www.metalfachtg.pl/zglos-problem-online) or hotline +48 85 711 94 54 ext. 17).
3. It is recommended to refrain from using the defective device.
4. The user is obliged to provide free access to the device (in particular, enabling removal of the device casing and access to valves).
5. Warranty repairs will be performed by the Guarantor or a specialist company indicated by the Guarantor.
6. The obligations arising from the warranty will be fulfilled within 14 business days from the date the device is made available (at the place of installation) by the User.
7. The date of making the device available is agreed between the User and the Guarantor.
8. Depending on the scope of the repair, it may be performed at the User's place, at the place of installation of the device, or at the Guarantor's plant or a specialist company performing activities on behalf of the Guarantor.
9. Any repair performed under warranty must be confirmed in the warranty card.
10. The warranty is extended by the time during which the user was unable to use the device due to a defect in the device covered by the warranty.

11. The warranty does not exclude, limit or suspend the buyer's rights arising from the provisions on warranty for defects in the sold item.

Confirmation of inspection, warranty repair and service

	Date of execution	Description of activities performed	Signature and stamp of the contractor
1.			
2.			
3.			
4.			
5.			
6.			

	Date of execution	Description of activities performed	Signature and stamp of the contractor
7.			
8.			
9.			
10.			
11.			
12.			

EC/EU declaration of conformity**Producer:**

METAL-FACH Technika Grzewcza Sp. z o. o .
 Street Sikorskiego 66
 16-100 Sokółka
 NIP 545-182-60-12

Product name and purpose:

Steel central heating boiler for solid fuel with automatic fuel charging.

Type:	SEMAX BASIC
-------	-------------

Factory number:	
-----------------	--

Year of production:	
---------------------	--

The above-mentioned subject matter of this EU declaration of conformity is in compliance with the relevant requirements of EU harmonization legislation .

Reference documents:

1. Directive 2006/42/EC of the European Parliament and of the Council of 17 May 2006 on machinery
2. Directive 2014/30/EC of the European Parliament and of the Council of 26 February 2014 on the harmonization of the laws of the Member States relating to electromagnetic compatibility
3. Directive 2014/68/EU of the European Parliament and of the Council of 15 May 2014 on the harmonization of the laws of the Member States relating to the making available on the market of pressure equipment
4. Directive 2014/35/EU of the European Parliament and of the Council of 26 February 2014 on the harmonization of the laws of the Member States relating to the making available on the market of electrical equipment designed for use within certain voltage limits
5. /Commission Regulation (EU) No 2015/1189
 Directive 2009/125/EC of the European Parliament and of the Council of 21 October 2009 laying down general principles for establishing ecodesign requirements for energy-related products
6. /Commission Regulation (EU) No 2015/1187
 Directive 2010/30/EU of the European Parliament and of the Council of 19 May 2010 on the indication by labeling and standard product information of the consumption of energy and other resources by energy-related products
7. /Commission Regulation (EU) No 2015/863 (ROSHIII)
 Directive 2011/65/EU of the European Parliament and of the Council of 8 June 2011 on the restriction of the use of certain hazardous substances in electrical and electronic equipment
8. /Regulation E (EC) No 1907/2006 of the European Parliament and of the Council of 18 December 2006

Technical Documentation:

1. Standard PN-EN 303-5:2021-09 Solid fuel heating boilers with manual and automatic fuel charging with a nominal power of up to 500 kW.
2. PN EN 1708-1:2010 Welding Basic solutions for steel welded joints Part 1. Pressure elements.
3. PN EN 60335-1 2012 Household and similar electrical appliances Safety in use Part 1: General requirements.
4. PN EN 60335-2-102 2006/A 1:2010 - Household and similar electrical appliances - Safety in use - Part 2-102: Particular requirements for appliances burning gas, oil and solid fuels and having electrical connections.
5. PN EN 61000-6-2:2008 Electromagnetic compatibility (EMC) - Part 6-2: General standards - Immunity in industrial environments.

6. PN EN 61000-6-3:2008/A 1:2012 Electromagnetic compatibility (EMC) - Part 6-3. General Standards -- Emission standard for residential, commercial and light industrial environments.
7. PN-EN IEC 63000:2019-01 Technical documentation for the assessment of electrical and electronic products with regard to the limitation of hazardous substances.

This declaration of conformity is issued under the sole responsibility of the manufacturer.

The product is marked with the following symbols:

Place and date:



Sokolka, 10.2023

Approvers:

Chairman of the Board:
Jacek Kucharewicz

A handwritten signature in blue ink, appearing to read 'Jacek Kucharewicz', is written over a logo. The logo consists of a square containing the letters 'MF' and a stylized 'E'.

PREZES ZARZADU
Jacek Kucharewicz

Production director
(Person authorized to prepare
technical documentation):
Julian Żukowski

A handwritten signature in black ink, appearing to read 'Julian Żukowski', is written over a logo. The logo consists of a square containing the letters 'MF' and a stylized 'E'.

**DYREKTOR
PRODUKCJI**
Julian Żukowski

Warranty Card

Central heating boiler with power [kW]: _____ Type: _____

Number: _____

Central heating boiler production date : _____ Boiler sales date: _____

Buyer's name and surname: _____

Buyer's address

Date of purchase and stamp

Customer's signature

I accept the warranty conditions

√

Personal data provided in this form are processed by Jacek Kucharewicz running a business under the name METAL-FACH Technika Grzewcza Sp. z o. o ., 16-100 Sokółka, ul. Sikorskiego 66, NIP: 545-182-60-12, telephone +48 85 711 94 54 ext. 17 in order to implement the provisions contained in the warranty conditions - in accordance with the Act of August 29, 1997 on the protection of personal data (consolidated text: Journal of Laws . 2014, item 1182). The User has the right to access the content of his or her personal data, to correct it, to submit a request to discontinue data processing and to object to data processing in cases indicated by law. All correspondence regarding the processing of personal data should be sent to the following address: METAL-FACH Technika Grzewcza Sp. z o. o ., 16-100 Sokółka, ul. Sikorskiego 66. Providing personal data is voluntary. In accordance with the Act of August 29, 1997 on the protection of personal data (consolidated text: Journal of Laws of 2014 , item 1182), we would like to inform you that personal data provided in this form will be protected against access by unauthorized persons.

The complaint

Customer data	Central heating boiler data	
First name and last name	Product name:	
Address	Model:	
Telephone	No. factory	
No. purchase document:	Guarantee period	Includes Does not include
No. debt settlement document:	Detailed description of the fault:	
Seller's signature		

Conditions for starting the complaint repair procedure:

1. Confirmation by the point of sale of payment for the complained product constitutes the basis for initiating the complaint procedure.
2. The warranty card is the only basis for free repair.
3. The person filing the complaint undertakes to reimburse the costs incurred by METAL-FACH Technika Grzewcza Sp. z o. o . In the event of an unjustified call to the service team, or failure to complete points 1 or 2 (each commenced hour of service technician's work PLN 70 net, travel PLN 1 net/km both ways).
4. A legible signature of the applicant confirms that he or she has read the basic terms and conditions of complaint procedures.

Legible signature of the person submitting the complaint		Signature of the person accepting the complaint
--	--	---

I declare that I have read the warranty conditions based on which I am submitting a complaint and I consent to the processing of my personal data for the purposes of the complaint process in accordance with the Act of August 29, 1997 on Personal Data Protection (Journal of Laws No. 133, item 833). .

Legible signature of the person submitting the complaint
--

The manufacturer undertakes to perform warranty repairs within 14 days from the date of receipt of the user's written report of damage on the manufacturer's complaint form.

METAL-FACH Heating Technology

Personal data provided in this form are processed by Jacek Kucharewicz running a business under the name METAL-FACH Technika Grzewcza Sp. z o. o ., 16-100 Sokółka, ul. Sikorskiego 66, NIP: 545-182-60-12, telephone +48 85 711 94 54 ext. 17 in order to implement the provisions contained in the warranty conditions - in accordance with the Act of August 29, 1997 on the protection of personal data (consolidated text: Journal of Laws . 2014, item 1182). The User has the right to access the content of his or her personal data, to correct it, to submit a request to discontinue data processing and to object to data processing in cases indicated by law. All correspondence regarding the processing of personal data should be sent to the following address: METAL-FACH Technika Grzewcza Sp. z o. o ., 16-100 Sokółka, ul. Sikorskiego 66. Providing personal data is voluntary. In accordance with the Act of August 29, 1997 on the protection of personal data (consolidated text: Journal of Laws of 2014 , item 1182), we would like to inform you that personal data provided in this form will be protected against access by unauthorized persons.

Report on the first boiler start-up
(Copy of the owner of the central heating boiler)

In order to verify the purchase and recognize the validity of the warranty, a report must be sent within 30 days from the date of first launch. These activities can be performed by:

1. E-mail - where a scan or photo of the report will be posted.
2. A letter - in which a copy of the report will be sent to METAL-FACH Technika Grzewcza Sp. z o. o ., the company's address is at the end of the Technical and Operational Document.

Boiler	Fulfills	Does not meet	Comment
The conditions contained in the Operation and Maintenance Manual in the chapter "Requirements for the boiler room and boiler installation" are met.			
The conditions contained in the Operation and Maintenance Manual in the chapter "Connecting the boiler to the chimney" are met.			
Central heating system.	Fulfills	Does not meet	Comment
The conditions contained in the Operation and Maintenance Manual in the chapter "Connecting the boiler to the heating installation" are met.			
The conditions contained in the Operation and Maintenance Manual in the "Requirements for the expansion vessel " chapter are met.			
There is no other source of heating. If so, how does it affect the operation of the boiler?			
Protection of the system against freezing.			
Connecting elements with the electrical installation	Fulfills	Does not meet	Comment
The conditions contained in the Operation and Maintenance Manual in the chapter "Connecting the boiler to the electrical installation" are met.			
Equipment test	Fulfills	Does not meet	Comment
The sensors are located in the right place.			
Sensor readings are consistent with the actual condition.			
The direction of fan rotation is correct.			
Opening the fan flap using the force of the airflow.			
The direction of rotation of the screw is correct.			
Boiler start-up	Fulfills	Does not meet	Comment
The tightness of the boiler's hydraulic connection to the installation is maintained.			
System test (if installed).			
Checking the connection of the fuel feeder to the boiler.			
Filling the fuel tank with fuel.			
Checking the fuel supply through the feeder.			
Fire up the boiler in accordance with the "Boiler start-up" chapter.			
Initial adjustment of boiler operating parameters settings.			
Final adjustment of the boiler operating parameters settings.			
Confirmation of user training in the field	Yes	No	Comment
User instructions on how to safely operate the boiler are			

METAL-FACH Heating Technology

included in the "Remember when using the boiler" chapter.

Instructions on how to use the boiler regulator and how to regulate the combustion process.

Fan speed settings.

Boiler maintenance, chapter "Cleaning and maintenance of the boiler"

Required fuel quality, chapter "Fuel"

Procedure in emergency cases, chapter "Examples of device failure"

Launch date	Boiler name	Boiler power [kW]	Factory number
Name and surname of the service technician		Owner's name and surname	
Address		Address	
Company stamp		Contact number	
Signature		Signature	

Personal data provided in this form are processed by Jacek Kucharewicz running a business under the name METAL-FACH Technika Grzewcza Sp. z o. o ., 16-100 Sokółka, ul. Sikorskiego 66, NIP: 545-182-60-12, telephone +48 85 711 94 54 ext. 17 in order to implement the provisions contained in the warranty conditions - in accordance with the Act of August 29, 1997 on the protection of personal data (consolidated text: Journal of Laws . 2014, item 1182). The User has the right to access the content of his or her personal data, to correct it, to submit a request to discontinue data processing and to object to data processing in cases indicated by law. All correspondence regarding the processing of personal data should be sent to the following address: METAL-FACH Technika Grzewcza Sp. z o. o ., 16-100 Sokółka, ul. Sikorskiego 66. Providing personal data is voluntary. In accordance with the Act of August 29, 1997 on the protection of personal data (consolidated text: Journal of Laws of 2014 , item 1182), we would like to inform you that personal data provided in this form will be protected against access by unauthorized persons.

Report on the first boiler start-up **(Copy of METAL-FACH Technika Grzewcza)**

In order to verify the purchase and recognize the validity of the warranty, a report must be sent within 30 days from the date of first use. These activities can be performed by:

1. E-mail - where a scan or photo of the report will be posted.
2. A letter - in which a copy of the report will be sent to METAL-FACH Technika Grzewcza Sp. z o. o ., the company's address is at the end of the Technical and Operational Document.

Boiler	Fulfills	Does not meet	Comment
The conditions contained in the Operation and Maintenance Manual in the chapter "Requirements for the boiler room and boiler installation" are met.			
The conditions contained in the Operation and Maintenance Manual in the chapter "Connecting the boiler to the chimney" are met.			
Central heating system.	Fulfills	Does not meet	Comment
The conditions contained in the Operation and Maintenance Manual in the chapter "Connecting the boiler to the heating installation" are met.			
The conditions contained in the Operation and Maintenance Manual in the "Requirements for the expansion vessel " chapter are met.			
There is no other source of heating. If so, how does it affect the operation of the boiler?			
Protection of the system against freezing.			
Connecting elements with the electrical installation	Fulfills	Does not meet	Comment
The conditions contained in the Operation and Maintenance Manual in the chapter "Connecting the boiler to the electrical installation" are met.			
Equipment test	Fulfills	Does not meet	Comment
The sensors are located in the right place.			
Sensor readings are consistent with the actual condition.			
The direction of fan rotation is correct.			
Opening the fan flap using the force of the airflow.			
The direction of rotation of the screw is correct.			
Boiler start-up	Fulfills	Does not meet	Comment
The tightness of the boiler's hydraulic connection to the installation is maintained.			
System test (if installed).			
Checking the connection of the fuel feeder to the boiler.			
Filling the fuel tank with fuel.			
Checking the fuel supply through the feeder.			
Fire up the boiler in accordance with the "Boiler start-up" chapter.			
Initial adjustment of boiler operating parameters settings.			
Final adjustment of the boiler operating parameters settings.			
Confirmation of user training in the field	Yes	No	Comment
User instructions on how to safely operate the boiler are			

METAL-FACH Heating Technology

included in the "Remember when using the boiler" chapter.

Instructions on how to use the boiler regulator and how to regulate the combustion process.

Fan speed settings.

Boiler maintenance, chapter "Cleaning and maintenance of the boiler"

Required fuel quality, chapter "Fuel"

Procedure in emergency cases, chapter "Examples of device failure"

Launch date	Boiler name	Boiler power [kW]	Factory number
Name and surname of the service technician		Owner's name and surname	
Address		Address	
Company stamp		Contact number	
Signature		Signature	

Personal data provided in this form are processed by Jacek Kucharewicz running a business under the name METAL-FACH Technika Grzewcza Sp. z o. o ., 16-100 Sokółka, ul. Sikorskiego 66, NIP: 545-182-60-12, telephone +48 85 711 94 54 ext. 17 in order to implement the provisions contained in the warranty conditions - in accordance with the Act of August 29, 1997 on the protection of personal data (consolidated text: Journal of Laws . 2014, item 1182). The User has the right to access the content of his or her personal data, to correct it, to submit a request to discontinue data processing and to object to data processing in cases indicated by law. All correspondence regarding the processing of personal data should be sent to the following address: METAL-FACH Technika Grzewcza Sp. z o. o ., 16-100 Sokółka, ul. Sikorskiego 66. Providing personal data is voluntary. In accordance with the Act of August 29, 1997 on the protection of personal data (consolidated text: Journal of Laws of 2014 , item 1182), we would like to inform you that personal data provided in this form will be protected against access by unauthorized persons.



METAL-FACH
HEATING TECHNOLOGY



Online form:

https://b2b.metalfachtg.com.pl/commission/createFromShortcut/shortcut_id/2



Video instructions:

www.youtube.com/c/METALFACHTechnikaGrzewcza



Web page:

www.metalfachtg.com.pl

Service contact:

st. Sikorskiego 66, 16-100 Sokółka
phone: +48 85 711 94 54 ext. 17
e-mail: p.czepiel@metalfach.com.pl

Producer:

METAL-FACH Technika Grzewcza Sp. z o.o.
st. Sikorskiego 66, 16-100 Sokółka
NIP: 545-182-60-12, REGON: 523566030
www.metalfachtg.com.pl